

## TUMBLE DRYERS

WHEN INVESTING MEANS SAVING

DD23 GOLD

### FEATURES

- Construction in grey skinplate, stainless steel look.
- Big loading door (opening of 180°).
- Direct drive through a gearbox, no pulley.
- ENERGY SAVINGS: Air recovery system for great energy efficiency.
- CARE DRY: The intelligent humidity sensor offers a precise control of the moisture in the linen. By this system the drying cycle will automatically stop when it reaches the set level of residual moisture.
- INSULATED PANELS & DOUBLE DOOR GLASS: The complete circuit of the air-flow has been thermally insulated in order to optimize the energy to heat the air and to maximize the energy efficiency. Double doorglass.
- OPTIMAL FLOW: The range of GOLD dryers complements the axial-radial air flow with side and front openings to increase and optimize the airflow circuit, achieving the most efficient drying conditions.
- SPRINKLER: Integrated Fire Extinguishing System.
- ELECTRONIC CONTROL: Easy and intuitive to use, the electronic control offers a complete control of the process.
- REVERSING DRUM: All models offer the reverse turning of the drum.
- STAINLESS STEEL DRUM standard.
- GENTLE DRY: The new drum with stamped holes makes sure the linen is gently handled.
- New filter drawer with wide surface and improved airflow.
- Cool Down: Anti-wrinkle at the end of cycle.
- Models available in electric, gas or steam heating.



### OPTIONS

- Stainless steel body.
- Stainless steel front panel.
- Low pressure steam battery.
- Model versions in 60 Hz.
- Marine versions 440V III 50/60 Hz No neutral or 480V III 50/60 Hz No neutral.



Air recylé



Contrôle de l'humidité  
et réglage automatique  
du tambour



Carrosserie isolée



Double flux  
Axial & Radial



Système  
anti-feu



Hublot  
double vitrage

TECHNICAL DATA	UNIT.	DD23 GOLD	
<b>CAPACITY</b>			
Capacity 1/18	Kg	26	
Capacity 1/20	Kg	23	
Hourly Output GOLD	Kg/h	60	
Evaporation capacity GOLD	l/h	35,1	
<b>DRUM</b>			
Ø Drum	mm	855	
Ø Door	mm	574	
Door center height	mm	1.030	
Load hole bottom height	mm	743	
Drum length	mm	800	
Drum volume	l	460	
<b>POWER</b>			
Drum motor power	Kw	0,37	
Fan Motor Power GOLD	Kw	0,75	
Total Installed power GOLD	Kw	25,17	
Electric Heating (Installed power)	Kw	24	
Gas heating (installed Power) in KW	Kw	31	
Gas heating (installed el. power) GOLD	Kw	1,17	
Steam heating (Steam Power KW)	Kw	49,2	
Steam heating ( installed el. power) GOLD	Kw	1,17	
<b>CONNECTIONS</b>		<b>ELECTRICAL</b>	<b>STEAM / GAS</b>
Tension 230V - I + T	N° x mm2 / A	-	3 x 1,5 / 20A
Tension 230V - III + T	N° x mm2 / A	4 x 25 / 80A	4 x 1,5 / 20A
Tension 400V - III + N + T	N° x mm2 / A	5 x 10 / 40A	5 x 1,5 / 20A
Ø Gas inlet	BSP	1/2"	
Ø Steam inlet	BSP	1"	
Ø Condensed (Steam models)	BSP	1"	
<b>DIMENSIONS / PACKING DIMENSIONS</b>			
Width / Width	mm	890/970	
Depth / Depth	mm	1.245/1.345	
Height / Height	mm	1.812/1.940	
Height without heating battery	mm	-	
Net weight / Gross weight	Kg	210/230	
<b>OTHERS</b>			
Max airflow GOLD	m3/h	1.500	
Ø Fume exhaust	mm	200	
Sound level GOLD	dB	65	

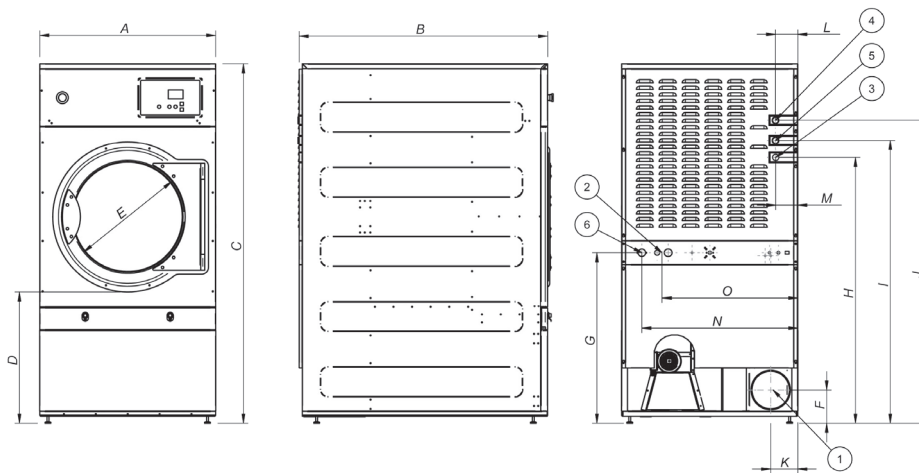

- 01. Fumes outlet
- 02. Electrical connection
- 03. Gas connection
- 04. Steam connection
- 05. Condensation outlet
- 06. Anti fire water valve

	A	B	C	D	E	F	G	H	I	J	K	L	M	N	O
DD23	890	1.245	1.817	672	574	168	862	1.344	1.430	1.532	137	113	112	787	685